

AMP CONDENSING BOILERS - SUBMITTAL DATA SHEET

RATINGS AND CAPACITIES		
Input - Low Fire	700,000	BTU/HR
Input - High Fire	3,500,000	BTU/HR
Output - High Fire	3,395,000	BTU/HR
Boiler Horsepower	101.4	BHP
Thermal Efficiency	97.0%	
Low Fire Thermal Efficiency	Up to 99%	
Fuel	Natural Gas	
Firing Rate	Full Modulation	
Burner Turndown	5:1	
Low NOx Emissions	< 10 ppm	
Inlet Gas Pressure (NG)	4" wc	Min.
	14" wc	Max.
Shipping Weight, Approximate	2,581	lbs

DIMENSIONS / CONNECTIONS	
- Height	55"
- Width	46"
- Length	97-1/8"
- Supply Connection	4" Grooved
- Return Connection	4" Grooved
- Vent / Air Intake Connections	12"
- Gas Connection	2" NPT

STANDARD EQUIPMENT	
- ASME Stainless Steel Heat Exchanger	
- Stainless Steel Pre-Mix Burner	
- Variable Speed Combustion Blower	
- Concert Boiler Control™ (24v)	
> 7" Color Touch Screen	
> Peer-To-Peer Boiler Communications (Up to 8 Units)	
> Energy Management System (EMS) Interface	
> USB Data Port Transfer	
> Self-Guiding Diagnostics	
> Unmatched Archives	
- High Limit Temperature Control, Manual Reset	
- Water Flow Switch	
- Low Water Cutoff, Manual Reset	
- Condensate Trap	
- Blocked Condensate Switch	
- Combustion Air Switch	
- Pressure Relief Valve	
- Pressure / Temperature Gauge	
- Supply & Return Temperature Sensors	
- Flue Gas Temperature Sensor	
- Modulating Gas Valve	
- Direct Spark Ignition and UV Scanner	
- High/Low Gas Pressure Switches, Manual Reset	
- 208v or 230v or 460v/3ph/60hz Line Voltage	
- Category IV Individual Venting	
- Category II Common Venting with Engineered Vent System	
- CPVC, Polypropylene & Stainless Steel Acceptable *Material	
- Sealed or Room Combustion Air Intake	

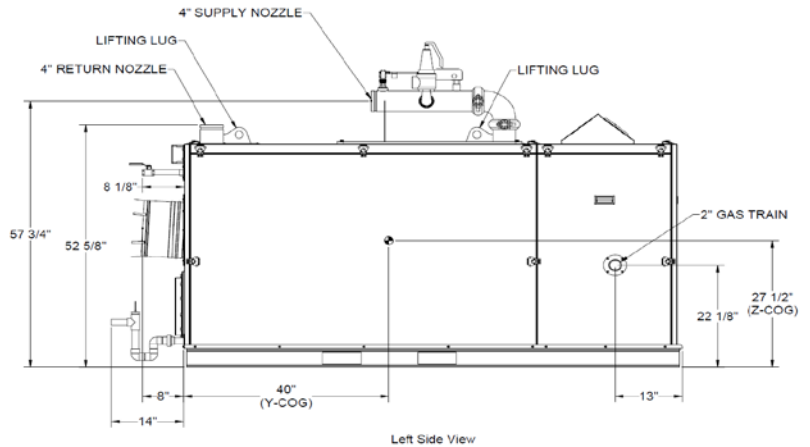
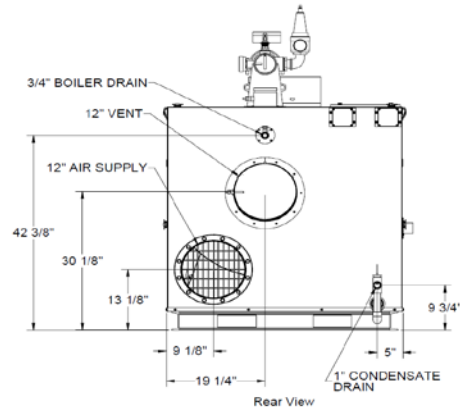
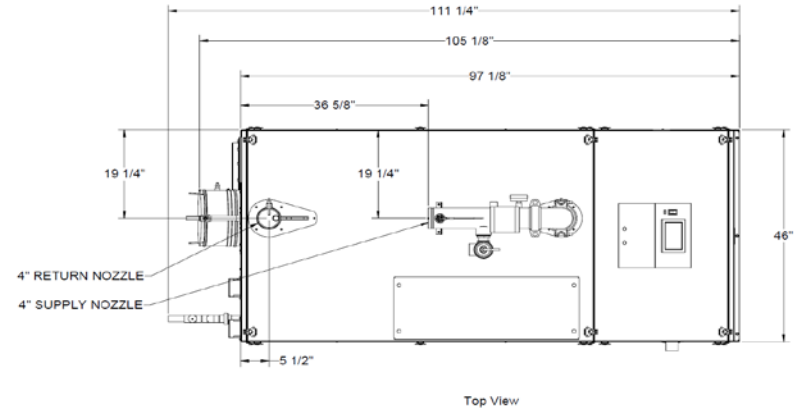
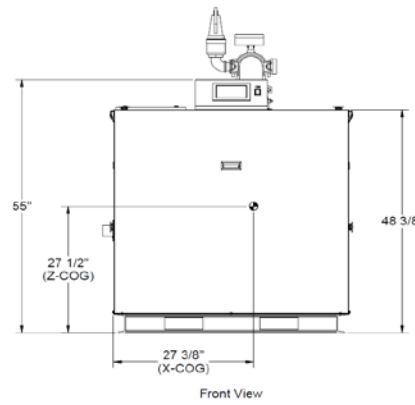

NOTES: 1. Dimensions shown are for reference only

FLOWS AND PRESSURE DROPS		
Delta T	Flow (GPM)	Δ P (Ft. Hd)
20°F Δ T (Max)	340	15.5
25°F Δ T	272	10.6
30°F Δ T	226	8.1
35°F Δ T	194	6.5
40°F Δ T	170	5.3
45°F Δ T	151	4.4
50°F Δ T	136	3.7
55°F Δ T (Min)	123	3.5

AMP-3500

PROPERTY OF

THERMAL SOLUTIONS
Innovative Equipment for Hot Water Systems

PO BOX 3244 | LANCASTER, PA 17601
 INNOVATIVE EQUIPMENT FOR
 HOT WATER SYSTEMS
WWW.THERMALSOLUTIONS.COM

* Flue system material shall be capable of continuous operation at 210°F or higher and shall be certified to UL 1738 – venting system for gas-burning appliances cat II, III and IV.